

AT CONSULTANTS PVT LTD JAMNAGAR



**DIE GRINDING
MACHINE**



TECHNICAL SPECIFICATION OF THE MACHINE

MODEL	PDG 500
Diameter of die	Ø100mm - Ø520mm
Width of Die	Up to 190mm
Groove width	10mm – 120mm
Die Material	Die Steel (D2, H11, H13 etc)
Hardness	60 HRC
Die Type	Ring Die (Half Die Optional)
Number of Axes	5 Axes
CNC Controller	Siemens 840D controller
Measuring System	Touch Probe (Renishaw Make)
Spindle Power	7.5KW (Optional 15KW)

A T Consultants Pvt Ltd,
Jamnagar, Gujarat has designed,
manufactured and successfully
commissioned many Die Grinding
and Mandrel Grinding Machines,
in India & Abroad.

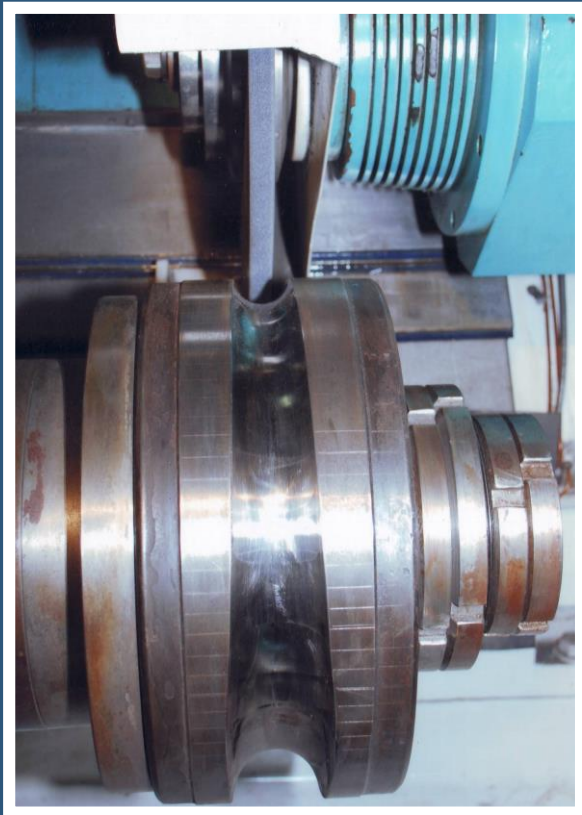

CUSTOMIZED SOFTWARE & ITS FEATURES

ATCPL designed and developed special software to produce die grooves with different profiles like straight-tapered, hyperbola, parabola, curves. Software will also handle tangential side relief grooves with corner radius and will ensure proper smoothness of complete groove surface.

Constant programmable surface speed, auto grinding wheel dressing with diamond roll, automatic dressing compensation, auto coordinate measuring with touch type Probe are few features of the software package

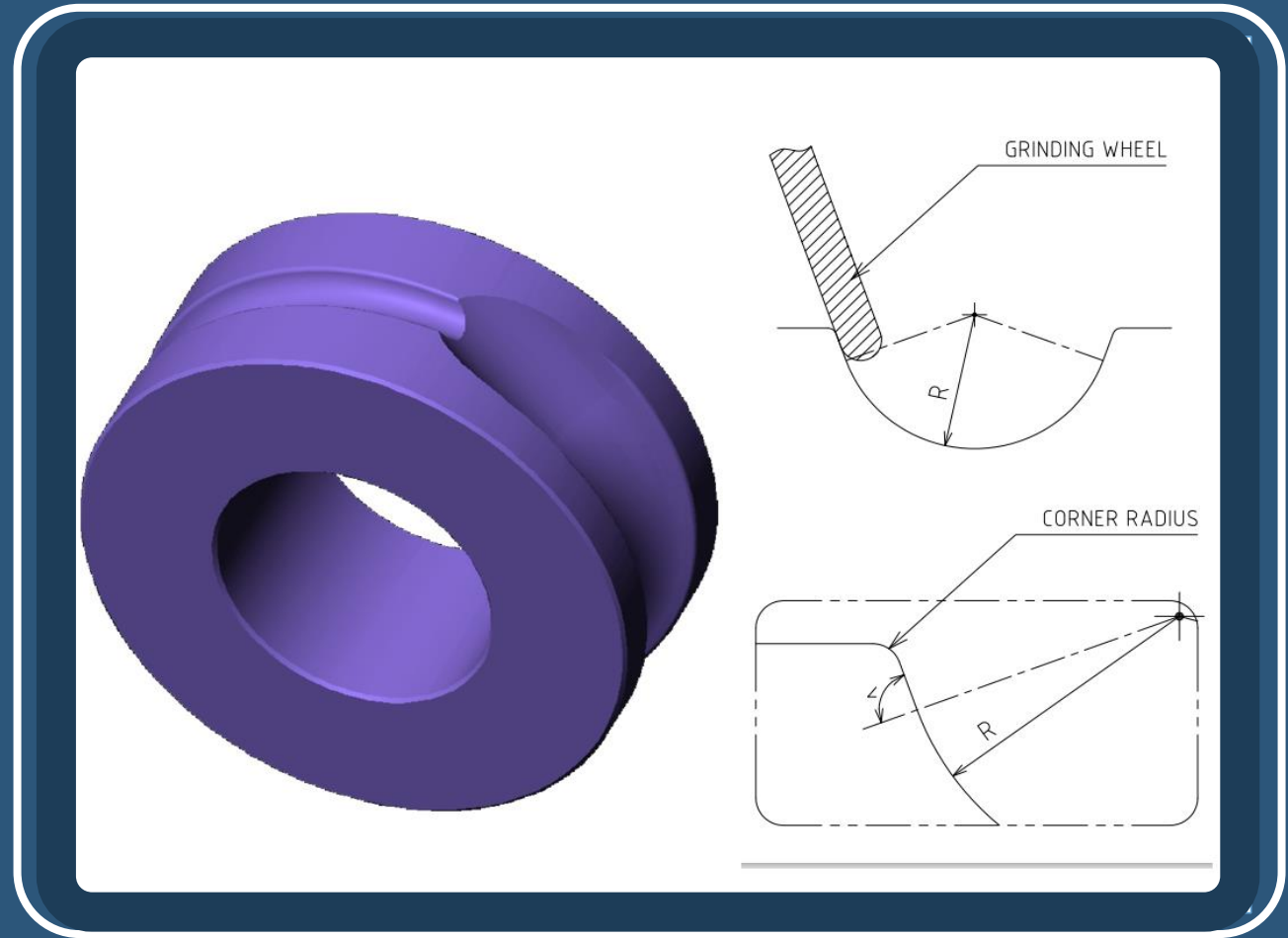

MOTORIZED GRINDING SPINDLE – (BUILT IN MOTOR)

High speed precision grinding spindle – built in motor, with Dynamic wheel balancer.

Variable Speed:

Special mounting flanges for different grinding wheel.

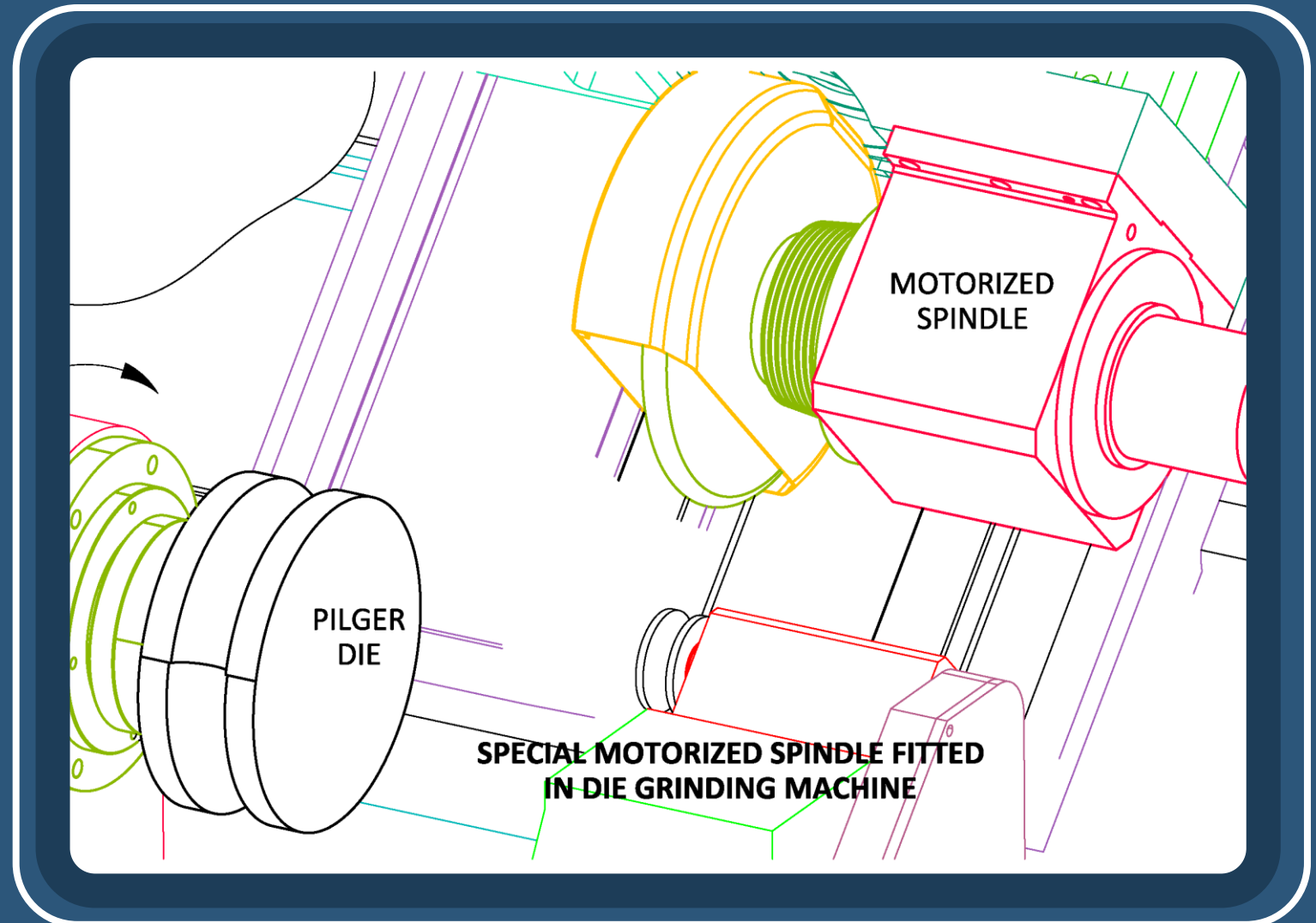

Fully enclosed machine.
Slide ways are protected
with SS telescopic covers

All Linear Axes fitted with
precision C3 class ground
Ballscrews. Positioning
feedback will be derived
from absolute linear scale

Rotary Axis is fitted
with precision P2 class
Spindle bearings and
backlash free drives.

**PDG
500**

Machine with touch type
measuring probe for
groove measurement and
correction cycles.

Flange type dynamic wheel
balancer fitted with
motorized spindle. Additional
static wheel balancer with
mandrel.

PILGER DIE & MANDREL GRINDING MACHINES

Image shows the machines installed at our customer's end.



FEW EMINENT CUSTOMERS

Choksi Tube Co Ltd; Ahmedabad

OCL India Ltd; Rajgangpur

TISCO; Jamshedpur

ISMT Ltd, Baramati

Ratnamani Metals & Tubes Ltd

Welspun Ltd; Bharuch

Sandvik Steel Ltd Ahmedabad

Viraj Profiles Ltd; Boisar

Mahindra UGINE Steel Co Ltd

Tubinox SA; Romania

L&T Ltd; Hazira Works

Chandan Steel Ltd; Umbergaon

Pishey Industries; Bangalore



THANK YOU!

A T Consultants Pvt Ltd
603, Swagat, P N Marg
Jamnagar, GJ, India



atcplcon@yahoo.com



<http://www.atcpl.com>



+91 98795 97099